

We Build Confidence...
In High-Resolution Large Character Printing

- High resolution (150 x 300 dpi) large character and bar code printing capability
- Dual-tasking printer allows control of up to two independent production lines
- Controls up to eight maintenance-free, auto-purge printheads
- Line speeds up to 200 feet per minute (61 m/min)
- Intuitive, graphical user interface with a touch screen controller

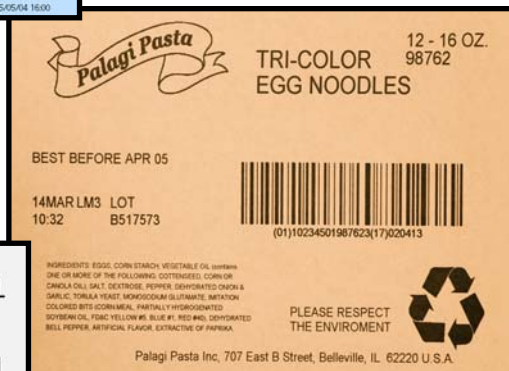

Get confident. Contact us today.

The most advanced system for carton coding solutions

Introducing the Marsh 8000™ printer

The Marsh 8000 system combines high resolution printing with a highly advanced user interface, making message creation quick, easy and error-free. The Marsh 8000 allows users to print with eight maintenance-free, auto-purge printheads providing maximum flexibility to either print on four sides of a box or print on two independent production lines simultaneously.

A familiar operating system that can also run on a PC

The Marsh 8000 controller software is designed for the Windows CE® operating system. The controller software can be readily run from a remote PC, allowing codes to be created off-line and then downloaded to single or multiple controllers via Ethernet or RS-232 connections. You can also create a centralized database of

messages from which codes and graphics can be accessed and stored. To reduce message selection errors, you can connect a bar code scanner to enter variable data or load messages. This new software is similar to the software used in other Videojet printers, allowing easy training for users.



High-resolution printing eliminates the need for pre-printed cartons

The Marsh 8000 system supports two models of printheads — EN120 (.8", 20mm) and the EN300 (2", 51mm) — to deliver on-line printing of graphics bar codes and True Type® fonts with character heights from 1/16" (1.5mm) to 2" (51mm) for full generic case coding, eliminating the need for pre-printed cartons or providing flexibility of dynamic printing of blank shippers. Maintenance-free auto-purge printheads use innovative, patented solvent wash technology to thoroughly clean print heads at pre-set intervals. Customers have the flexibility to set the auto-purge function, through software, to coincide with shift start, lunch or breaks to ensure maximum productivity. Solvent and waste is automatically collected from the print head face and deposited in an easy-to-discard refuse bottle.

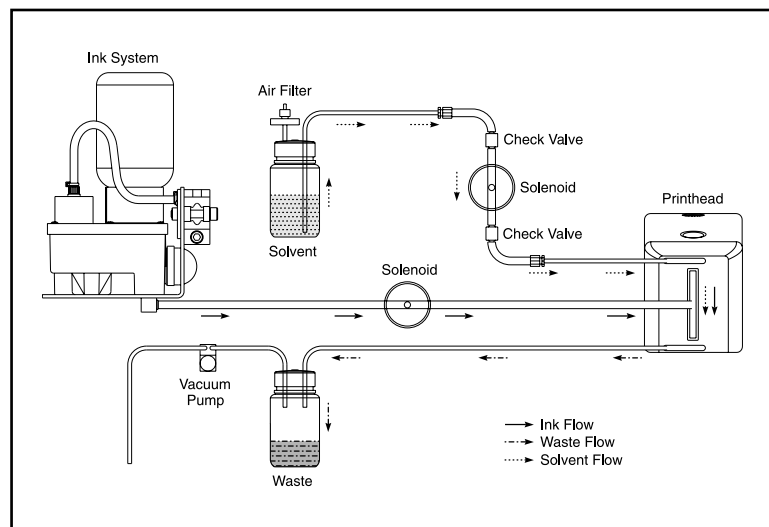

Auto Purge System



Intuitive, graphical, icon-based interface with WYSIWYG image editor

With the Marsh 8000 controller interface, message creation is fast and easy to learn. Drag-and-drop editing tools with cut and paste features and group alignment make creating messages a snap. The WYSIWYG image editor minimizes the risk of error.

Advanced options allow users to customize date and time formats, as well as alpha and shift codes, making the system flexible enough to address any customer specific requirements.

The power to perform

The Marsh 8000 system represents the next level in Videojet's printing technology through the use of an advanced user interface with full resolution image control and increased processing power. The Marsh 8000 system is extremely versatile, and it's processing power provides fast message changeover, even when using external devices to initiate message call-ups.

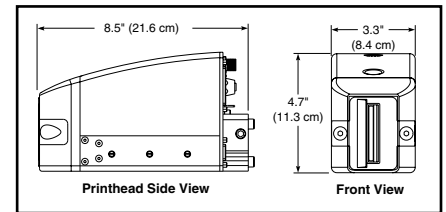
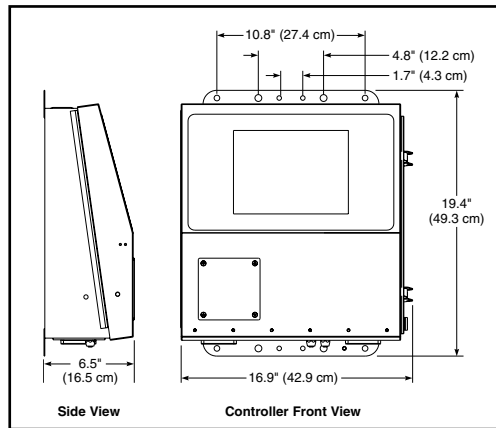

Specifications

Power Requirements

100 to 240 VAC; 3.0/1.5A; 47-83 Hz

Environment

40° - 120° F (4.4° - 49° C)

Stainless Steel Cabinet

Nema 12 / IP54 standard
Nema 4 / IP65 optional kit

Maximum Line Speed

Alphanumeric: 200 fpm (61mpm)
Bar codes, graphics: 150 fpm (45 mpm)

Print Resolution

Up to 150 dpi vertical
Up to 300 dpi horizontal, depending on line speed

Character Heights

1/16" (1.5 mm) min.
2" (51 mm) max.

Message Content

TrueType® fonts, up to 32 lines of print depending on font selected
Bar codes; Graphics

Bar code Symbolologies

Code 128; UCC/EAN128; Code 39;
1 2 of 5; 1 2 of 5 UCC/EAN; UPC-A;
EAN-13

Print Orientation

Horizontal, up, or down – standard heads
Horizontal only – auto-purge heads

Printheads

EN Series: EN120, .8" (20 mm) high
EN300, 2" (51 mm) high

Distance to print surface

Up to .25" (6.3 mm)

Housing

Controller – Stainless steel
Printheads – Metal and stainless steel

Input Device

Touch screen

Display

VGA Color LCD, 10.4" (26.4 cm) measured diagonally

Message Storage

40GB Hard Drive and 256MB for message, font, and graphic storage

Data Interface

Ethernet or RS232

Pharmaceutical Applications

Built-in 21CFR Part 11 Compliance

PC software requirements

Windows® NT, 2000 and XP

Dimensions

Controller: 16.9" (42.9 cm) wide x 6.5" (16.5 cm) deep x 19.4" (49.3 cm) high
Printhead: 8.5" (21.6 cm) long x 3.3" (8.4 cm) wide x 4.7" (11.3cm) high

Weight

Controller – 30 lbs. (13.6 kg)
Printhead – 5.75 lbs. (2.5 kg)

Ink System

Capillary feed 13 oz. (382 ml) reservoir

Inks Available

Series 2000
Black, Red, Green, Blue

Certifications

CE
FCC Part 15A
NEMA 12 – IP51
NEMA 4X – IP65 optional
CAN/CNA Std. c22.2 No. 950
ETL Listed in conformance w/ANSI/UL Std. 1950

© 2004 Videojet Technologies Inc. – All rights reserved. Videojet Technologies Inc.'s policy is one of continued product improvement. We reserve the right to alter design and/or specifications without notice. Videojet and Marsh are registered trademarks and Marsh 8000 is a trademark of Videojet Technologies Inc. Windows NT, 2000, XP and Windows are registered trademarks of Microsoft Corporation. True Type is a registered trademark of Apple Computer, Inc.

CERTIFIED
ISO 9001
DOCUMENTED QUALITY



800-843-3610 • www.videojet.com • info@videojet.com

Videojet Technologies Inc. • 1500 Mittel Boulevard
Wood Dale IL • 60191-1073 • USA
Phone: 630-860-7300 • Fax: 630-616-3623

For additional information, contact:

SSI Packaging Group- 1514 Brook Rd Richmond, VA
1-800-638-7447, www.ssipackaging.com

Part No. SL 000398
8000-1204-US
Printed in U.S.A.